

# DR20I4

LIQUID COOLED DIESEL GENERATOR SET

# WINPOWER

Est. 1925

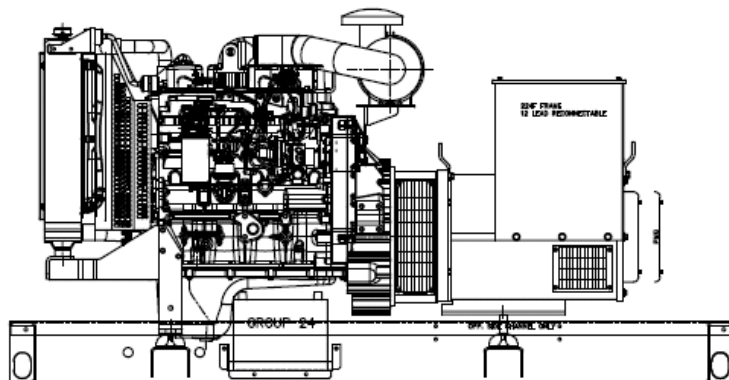

**Standby Rating**  
**20kW 60Hz**

Powered by ...  
**ISUZU**  
**4LE1**

**2.2 Liter**  
**Naturally Aspirated**

## EXPERIENCED DESIGN

- EXPERIENCE IN THE GENERATOR INDUSTRY SINCE 1925
- DESIGNED FOR LONG LIFE TO MAXIMIZE RETURN ON INVESTMENT
- WELDED AND POWDER COATED STEEL BASE
- RUBBER MOUNTED ENGINE AND GENERATOR: NO NEED FOR ISOLATION PADS AND EXTENDS THE LIFE OF BATTERIES AND HOUSING
- ELECTRICIAN FRIENDLY SINGLE COVER CONNECTION POINTS
- LOAD BANK TESTED
- SINGLE STEP 100% LOAD TESTED
- OPERATOR MANUAL PACKAGE INCLUDING ENGINE AND GENERATOR MANUAL
- STARTING BATTERY NOT INCLUDED (BCI 24 650 CCA)

## ENGINE

- INDUSTRY LEADER OF DIESEL ENGINES WORLDWIDE
- EPA COMPLIANT, INTERIM TIER 4
- COMPLETE SERVICE NETWORK
- EFFICIENT LOW FUEL CONSUMPTION DESIGN
- FILLED COOLING SYSTEM WITH 50/50 ANTIFREEZE
- CIRCULATING BLOCK HEATER

## DSE 7110 CONTROLLER

- GENERATOR PROTECTION AND METERING
- EVENT FAULT LOG RECORDING
- 7 CONFIGURABLE INPUTS
- 8 CONFIGURABLE OUTPUTS
- GLOW PLUGS AND STARTER SOLENOID CONTROLS.
- OPTIONAL DSE 3110 AND DSE 7310 CONTROLLERS PROVIDE FLEXIBILITY FOR ANY APPLICATION

## GENERATOR

- STANDBY RATED
- BRUSHLESS ROTATING FIELD
- WOUND 2/3 PITCH FOR LOW HARMONIC DISTORTION
- CLASS H WINDING INSULATION FOR PEAK PROTECTION
- MEETS BS EN 60034, BS5000, VDE 0530, NEMA MG1-32, ICE34, CSA C22.2-100, AS1359
- AS480 AUTOMATIC VOLTAGE REGULATION STANDARD STEADY STATE VOLTAGE +/- 1%
- OPTIONAL EXCITATION BOOST SYSTEM (EBS) SENSES DROPS IN VOLTAGE FROM LARGE IMPACT LIKE MOTOR STARTING. THE EBS ENGAGES THE EXCITATION BOOST GENERATOR FEEDING ADDITIONAL POWER TO THE GENERATORS EXCITATION SYSTEM SUPPORTING THE LOAD

# APPLICATION & ENGINEERING DATA



## ENGINE SPECIFICATIONS

MAKE .....	ISUZU
MODEL .....	4LE1
TYPE .....	DIESEL
GROSS HORSEPOWER-STANDBY .....	36 HP
INDIRECT INJECTION .....	MECHANICAL
SPEED GOVERNOR .....	MECHANICAL
CYLINDERS .....	4
TOTAL DISPLACEMENT .....	2.2L
BORE X STROKE .....	in 3.35 X 3.78
ASPIRATION .....	NATURAL
ENGINE COOLANT CAPACITY .....	3.0 qts
TOTAL COOLING CAPACITY .....	2.5 gal
FLYWHEEL (TEETH 108) .....	10 inches
ROTATION .....	CCW
LUBE OIL SPECIFICATION .....	API CF-CH4, ACEA E3-E5
OIL & FILTER REPLACEMENT .....	250 HRS
LUBE OIL CAPACITY .....	8.5 QTS
FUEL SPEC .....	D975 No 2 D
EXHAUST OUTLET SIZE @ MUFFLER .....	2.0 inches
ELECTRICAL SYSTEM (NEGATIVE GROUND) .....	12 VDC
ALTERNATOR .....	35 AMPS
BATTERY (NOT INCLUDED BCI 24) .....	.650 CCA

## ALTERNATOR SPECIFICATIONS

RATING .....	(125/40°C) STANDBY
TYPE .....	4 POLE – REVOLVING FIELD
SPEED .....	1800 rpm
INSULATION SYSTEM .....	CLASS H
SINGLE PHASE .....	4 LEAD
THREE PHASE .....	12 LEAD
STATOR WINDINGS .....	DOUBLE LAYER CONCENTRIC
PITCH .....	2/3
WAVEFORM DISTORTION .....	1.5%
TELEPHONE INTERFERENCE .....	<2.0%
EFFICIENCY PEAK .....	~92.5%
COUPLING .....	FLEXIBLE DISC
BEARINGS (MAINTENANCE FREE) .....	1
VOLTAGE CONTROL .....	(AS480 STANDARD) SELF EXCITED
REGULATION .....	+/- 1.0%
SINGLE PHASE RATING .....	1.0pf
THREE PHASE RATING .....	0.8pf

**Excitation Boost System Generator Available**

**If the information that you require is not shown, please contact your dealer.**

## GENERATOR CONTROLLER

### General

Deep Sea digital genset controllers are highly advanced microprocessor controllers. Each model is designed to stand up to the harshest conditions providing timely performance information and safety shutdowns. With so many options it is easy to find a controller flexible enough to meet your application. Some options may require activation through the free interface software or additional accessories. The DSE 7110 is standard.

Feature	DSE 3110	DSE 7110	DSE7310
<b>Engine Display/Protection</b>			
Engine RPM	X	X	X
Low Oil Pressure	Shutdown Only	X	X
High Coolant Temperature	Shutdown Only	X	X
Low Coolant Level	Optional	Optional	Optional
Overspeed	X	X	X
Underspeed	X	X	X
Overcrank	X	X	X
Charging Alternator Failure	Optional	X	X
CAN ECU Shutdown	X	X	X
<b>Genset Display/Protection</b>			
Voltage (L-N)	One L-N or L-L	X	X
Voltage (L-L)	One L-N or L-L	X	X
Overvoltage	X	X	X
Undervoltage	X	X	X
Frequency	X	X	X
Overfrequency	X	X	X
Underfrequency	X	X	X
Phase Imbalance	-	-	Disabled
Amp Display/Shutdown	-	X	X
kW, kVa, kVAr, pf Display	-	-	X
kWh, kVAh, kVArh Display	-	-	X
Generator Phase Sequence	-	-	X
Earth Current	-	-	Optional
<b>Additional Displays/Protections</b>			
Emergency Stop	X	X	X
Fuel Leak/Sender Failure	Optional	X	X
High Fuel Level	-	Optional	Optional
Low Fuel Level	Optional	X	X
Fuel Level	-	X	X
Battery Voltage	-	X	X
Battery Over/Under Voltage	-	X	X
Battery Charger Failure	-	Optional	Optional
<b>Communications</b>			
USB Connectable	X	X	X
RS232/RS485	-	-	X
NFPA Annunciator	-	-	10xDSE2548
Remote Display Panel	-	-	3xDSE2510
Ethernet/Modem	-	-	Optional
<b>Additional Features</b>			
Audible Alarm	-	-	X
Engine Exerciser	-	X	X
Maintenance Interval Timer	-	1 Event	3 Event
Load Shedding/Dummy	-	-	5 Step
Configurable Inputs	6	7	9-24w/DSE2130
Configurable Outputs	4	8	6-80w/DSE2751
Event Log	-	5	250
Alternative Configurations	1	1	3
UL/CSA Listed	X	X	X

### Electrical Output 20kW Standby

Output Voltage – 60Hz	kW	kVa	Amperes	CB Size
120/240, 1-phase, 1.0 pf	20	20	83	90
120/208, 3-phase, 0.8 pf	20	25	69	75
120/240, 3-phase, 0.8 pf	20	25	60	60
277/480, 3-phase, 0.8 pf	20	25	30	30

Consult factory for switchable voltage & 50 Hz

### Fuel Consumption

100% Load .....	1.80 Gallons/Hr
75% Load .....	1.40 Gallons/Hr
50% Load .....	0.90 Gallons/Hr

Winpower offers three UL142 double wall fuel tank options and a single wall composite fuel tank for this model. Double wall tanks include removable stub-up end plate as well as leak detection and digital fuel level indication.

### NFPA 110 Level 1 Package Option

This option provides a higher state of readiness in accordance with NFPA 110. Option includes a dual rate battery maintenance charger with failure indication, 16-light remote annunciator, low coolant level indication, block heater upgrade that maintains 100°-120°F and enhanced genset controller pre-alarm settings.

### Derating Factors

Temperatures > 104°F .....	3% per 10°F
Altitude .....	3% per 1000 ft
Prime Power .....	10%

### Engine Block Heater Specifications

- Volts – 120
- Watts – 1000
- Thermostat On/Off - 100°/120°F

### Limited Warranty

Winpower warrants its product from material defects for a period of one year or 1000 hours. Isuzu warrants the engine for standby generator applications for 36 months or 3000 hours with 60 months or 5000 hours on major components.

## OPTIONS AND ACCESSORIES

### Optional Fuel Accessories

- 32 gal (Composite)
- 55 gal UL142 Tank
- 110 gal UL142 Tank
- 155 gal UL142 Tank
- DOT Trailer w/Integrated Tank

### Battery Chargers

- 2 amp (Standard)
- 3.5 amp
- 6 amp
- 6 amp w/Fail Contact
- 10 amp
- 10 amp w/Fail Contact

### Enclosure Options

- POWR-PAK (Open skid, no enclosure)
- SOUND-PAK (69 dBA)

### Controller Options

- DSE 3110
- DSE 7110 (Standard)
- DSE 7310
- NFPA 110 Level 1
- 16 Light Remote Annunciator
- Remote Display Panel (DSE 2510)
- Ethernet
- DSE 2130 Input Expansion
- DSE 2751 Output Expansion

### Generator Accessories

- Anti-condensation Heater
- Excitation Boost System
- Oversized Generator
- 12 Lead (Double Delta) Single Phase

Distributed by

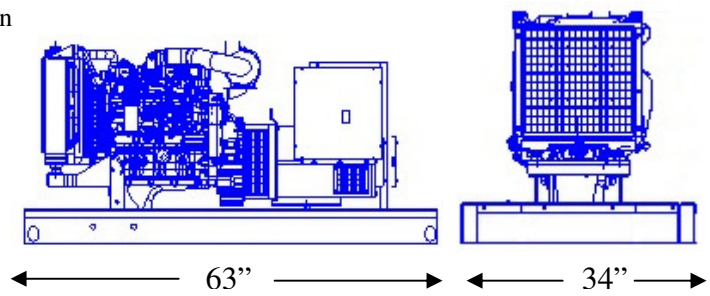

\*\*SPECIFICATIONS SUBJECT TO CHANGE WITHOUT NOTICE\*\*